



YOSHIMURA

RESEARCH&DEVELOPMENT OF AMERICA, INC.

5420 DANIELS STREET STE A, CHINO CA., 91710 · (800) 634-9166 · (909) 628-4722 · FAX (909) 591-2198

www.yoshimura-rd.com

Street Series

Qualified Manufacturer Declared "Replacement Part"

2016 Honda Africa Twin CRF1000 12400BD520 (SS/CF)

Works Finish RS-4 Stainless Steel Slip-On

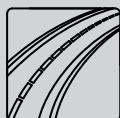

All Street Series systems are:

- Slip-on/Bolt-on applications that do not require tampering with the vehicle's emissions control system.
- CARB/EPA tail-pipe emissions compliant.
- Marked with appropriate EPA noise labels.
- Not tested for EPA new vehicle noise compliance.

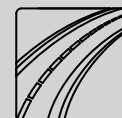

✘ *You must know how to remove and replace your stock exhaust in order to install this product otherwise have it installed by a professional mechanic. Keep all stock parts from your existing system as some components may be necessary to install your new Yoshimura exhaust depending on the application. Read through all instructions before beginning installation. Exhaust system can be extremely hot. Let motorcycle cool down before beginning installation. Always wear hand and eye protection and take precautionary measures to avoid injury.* ✘

NOTE: IN THE STATE OF CALIFORNIA, IT IS ILLEGAL TO MODIFY THE EMISSION CONTROL SYSTEM, WHICH INCLUDES THE CARBURETORS OF ANY VEHICLE.

Assembly Diagram

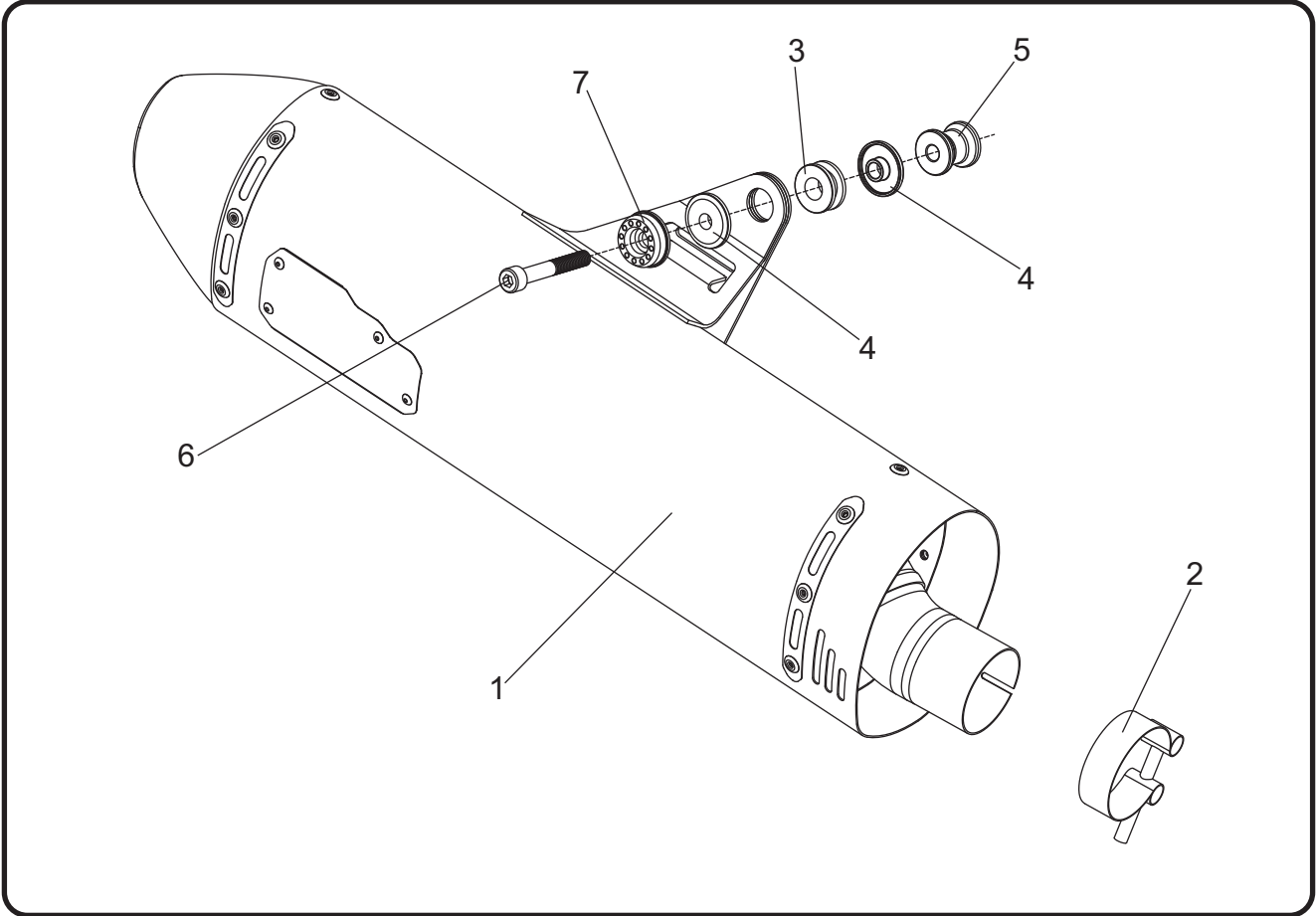

No.	Item	Description	Qty.
1	12400BD520-RMA	Yoshimura Muffler Assembly	1
2	20062	Exhaust Clamp	1
3	Z1023	Rubber Grommet	1
4	ALS-043	Aluminum Spacer	2
5	8X25SPCR	Aluminum Spacer	1
6	M8X55	8mm x 55mm Socket Head Cap Bolt	1
7	M8ALCSW-00	Aluminum Countersink Washer	1
**	INS-26-K	Low Volume Sound Insert	1
**	347PLUG	Yoshimura Wash Plug	1
**	17029	Sticker Kit Sheet	1

** Not shown in diagram.

CAUTION: Exhaust system can be extremely hot. Let motorcycle cool down before beginning installation. Always wear hand and eye protection and take precautionary measures to avoid injury.

WARNING: Always properly support vehicle with a stand and/or lift when servicing or performing any work. Unstable vehicles may present dangerous conditions and may cause property damage and/or personal injury.

NOTE: Read through all instructions before beginning installation.

Removal

1. Remove the stock plastic outer heatshield and inner metal header heatshield to access muffler exhaust clamp.
2. Loosen muffler exhaust clamp.
3. While securely supporting the stock muffler assembly, remove the muffler mount bolt and carefully remove the stock muffler assembly.

Note: The stock exhaust gasket will not be used with the Yoshimura slip-on system.

Installation

1. Re-install the stock inner and outer header heatshields using the opposite steps of removal. Do not torque heatshield bolts at this time.
2. Slide (No. 2) 20062, exhaust clamp over (No. 1) 12400BD520-RMA, muffler tailpipe inlet. Do not torque exhaust clamp at this time.
3. Install (No. 3) Z1023, rubber grommet into muffler bracket.
4. Install (No. 4) ALS-043, aluminum spacers into (No. 3) Z1023, rubber grommet as shown.

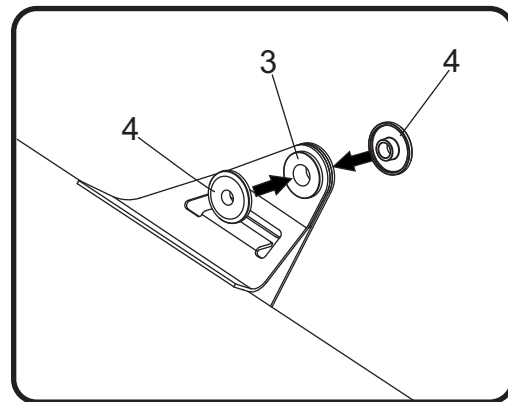

5. Install (No. 1) 12400BD520-RMA, muffler assembly over the stock header outlet and secure muffler to chassis using (No. 6) M8X55, bolt (No. 7) M8ALCSW-00, countersink washer, and (No. 5) 8X25SPCR, aluminum spacer as shown.

Note: The end of the Yoshimura muffler should align with the stock header heatshields. If touching, adjust heatshield or muffler as necessary. Torque muffler mount bolt and heatshield bolts to factory specifications when desired alignment has been achieved.

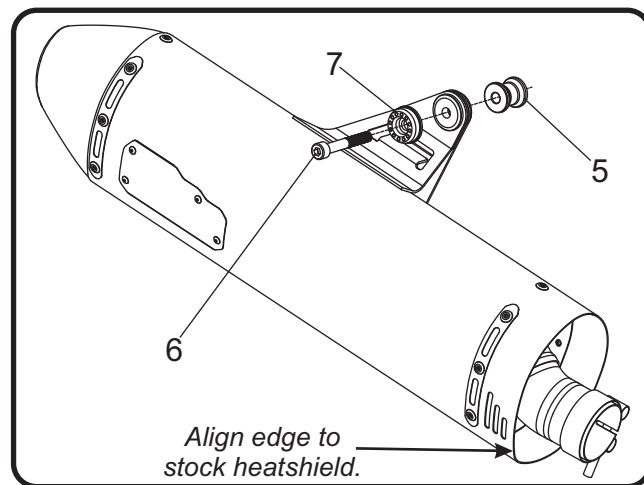

6. Torque (No. 2) 20062, exhaust clamp to 8.5 Nm (0.86 kg-m, 6 ft-lb).
7. Before starting vehicle, check for proper clearance between new exhaust system and rear suspension (i.e. tire, swingarm, brakes, rear shock, and etc.) If any problem is found, please carefully follow through the installation steps again. If problem still persists, please call Yoshimura Tech Department at (800) 634-9166 / in CA (909) 628-4722.

8. It is recommended that the muffler and tailpipe be wiped down with rubbing alcohol to remove oil and fingerprints. This will help prevent tarnishing of the finish after the exhaust is heated up.

Note: After starting vehicle, it is normal for new exhaust system and muffler to emit smoke until oil residue burns off.

Works Finish Care & Maintenance

Before starting vehicle, clean pipe thoroughly using a soft cloth and rubbing alcohol to remove any oil and finger prints.

The color of the exhaust will change once the system has gone through a heat cycle of 15 minutes or more. Color will vary depending on lean/rich conditions.

Clean using a soft cloth and soap. Do not use abrasive materials as it will scratch the surface.

Surface reconditioning services are available to remove scratches and undesirable discoloration due to extreme heat. Contact Yoshimura Tech Department at (800) 634-9166 / in CA (909) 628-4722 for more information.